

Connections: NPT – Socket Weld – Other
Options: Handwheel, Bronze, 'T' Bar, Stainless Steel Spindle

■ **Pressures:** 50 MPa
 Working: 40 MPa @ 100°C
 7 MPa @ 220°C

■ **Services:** Instrumentation &
 Hydraulic Medias
 Steam: 7000 kPa @ 350°C – BC791

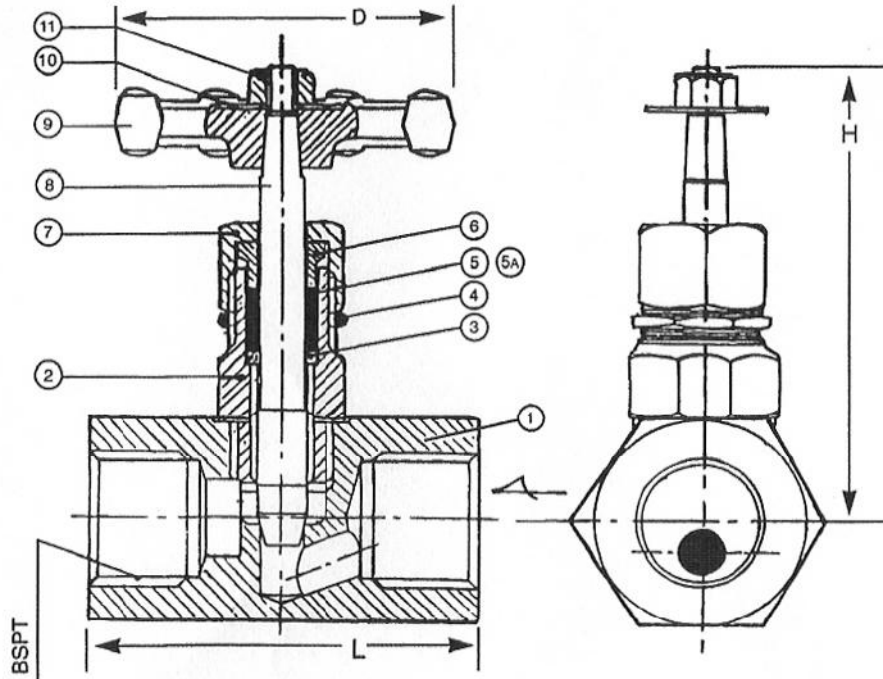

Carbon Steel
 Materials Plated

Dimensions

Size mm	8	10	15	20	25	32	40	50	65	80	100
L	51	51	77	82	95	127	127	TBA	.	.	.
H	77	77	77	110	110	190	190	TBA	.	.	.
D	65	65	65	90	90	150	150	TBA	.	.	.
Wt/kgs	0.4	0.4	0.6	1.2	1.5	4.0	4.0	TBA	.	.	.

Sizes: 32-40-50mm
 Square Body

Cv – Flow Data
 Refer
 Drawing #112-113BC

ITEM	DESCRIPTION	MAT'L	STANDARD
11	HANDWHEEL NUT	BRASS	STAINLESS
10	NAMEPLATE	ALUMINIUM	
9	HANDWHEEL	ZINC ALUM	AS1874
8	SPINDLE	CARBON STEEL	AS1443 12L14
7	GLAND NUT	CARBON STEEL	AS1443 12L14
6	GLAND	STAINLESS STEEL	ASTM A276 AISI316
5A	GLAND PACKING	GRAPHOIL	
5	GLAND PACKING	PTFE	AS1198
4	LOCK NUT	BRASS LP	
3	SEAL RING	STAINLESS STEEL	ASTM A276 AISI316
2	COVER – BONNET	CARBON STEEL	AS1443 12L14
1	BODY	CARBON STEEL	AS1443 12L14

PVA PROMET VALVES AUSTRALIA
 1A Green Road Woodville West SA 5011
 www.prometvalves.com promet@prometvalves.com
 T: 08 8268 1777 ABN 47096 425 697 F: 08 8268 1711

FIG No
BC792 CARBON STEEL NEEDLE
 VALVE PN